

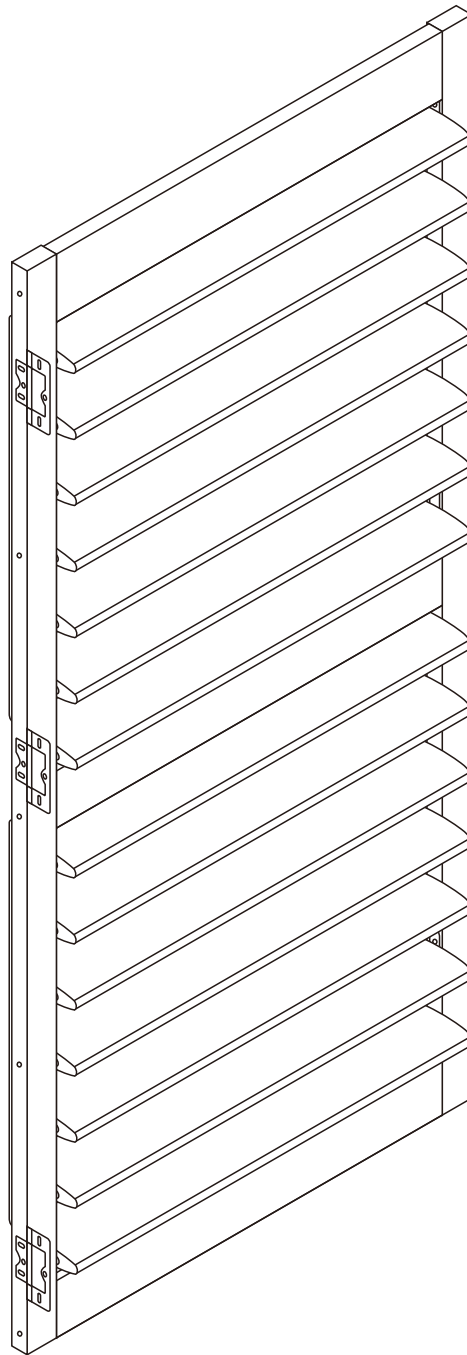

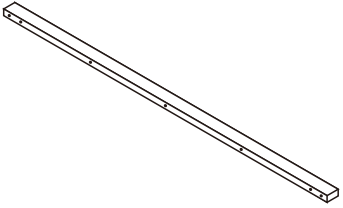

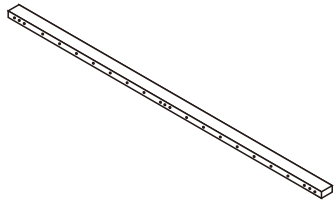

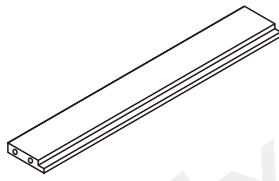

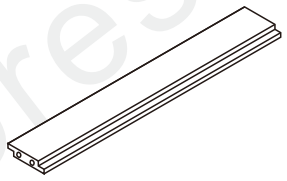
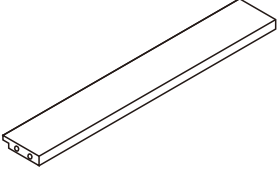
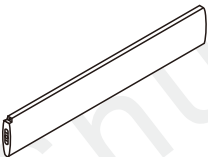
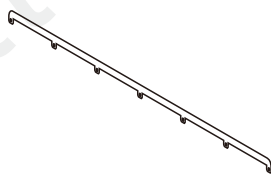

AUSSIE SHUTTER
EXPRESS.com.au

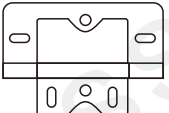
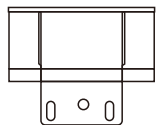
Shutter Kit Assembly Instructions



<p>Left Stile</p>  <p>1pc</p>	<p>Right Stile</p>  <p>1pc</p>	<p>Top Rail</p>  <p>1pc</p>	<p>Mid Rail</p>  <p>1pc</p>
<p>Bottom Rail</p>  <p>1pc</p>	<p>Blade</p>  <p>14pcs</p>	<p>Tilt Rod</p>  <p>2pcs</p>	<p>Assemble Screw</p>  <p>3. 8x105mm</p> <p>6pcs</p>
<p>Blade Pin</p>  <p>24pcs</p>	<p>Tension Screw</p>  <p>3. 8x63mm</p> <p>4pcs</p>	<p>Hinge Screw</p>  <p>3. 8x23mm</p> <p>18pcs</p>	<p>Normal Hinge</p>  <p>3pcs</p>
<p>HS L Hinge</p>  <p>Only for Hangstrip</p> <p>3pcs</p>	<p>Tension Washer</p>  <p>4pcs</p>	<p>Tilt Rod Screw</p>  <p>2x22mm</p> <p>14pcs</p>	<p>Screw Cover</p>  <p>10pcs</p>
<p>Plastic Dowel</p>  <p>12pcs</p>			

Step 1

Front View

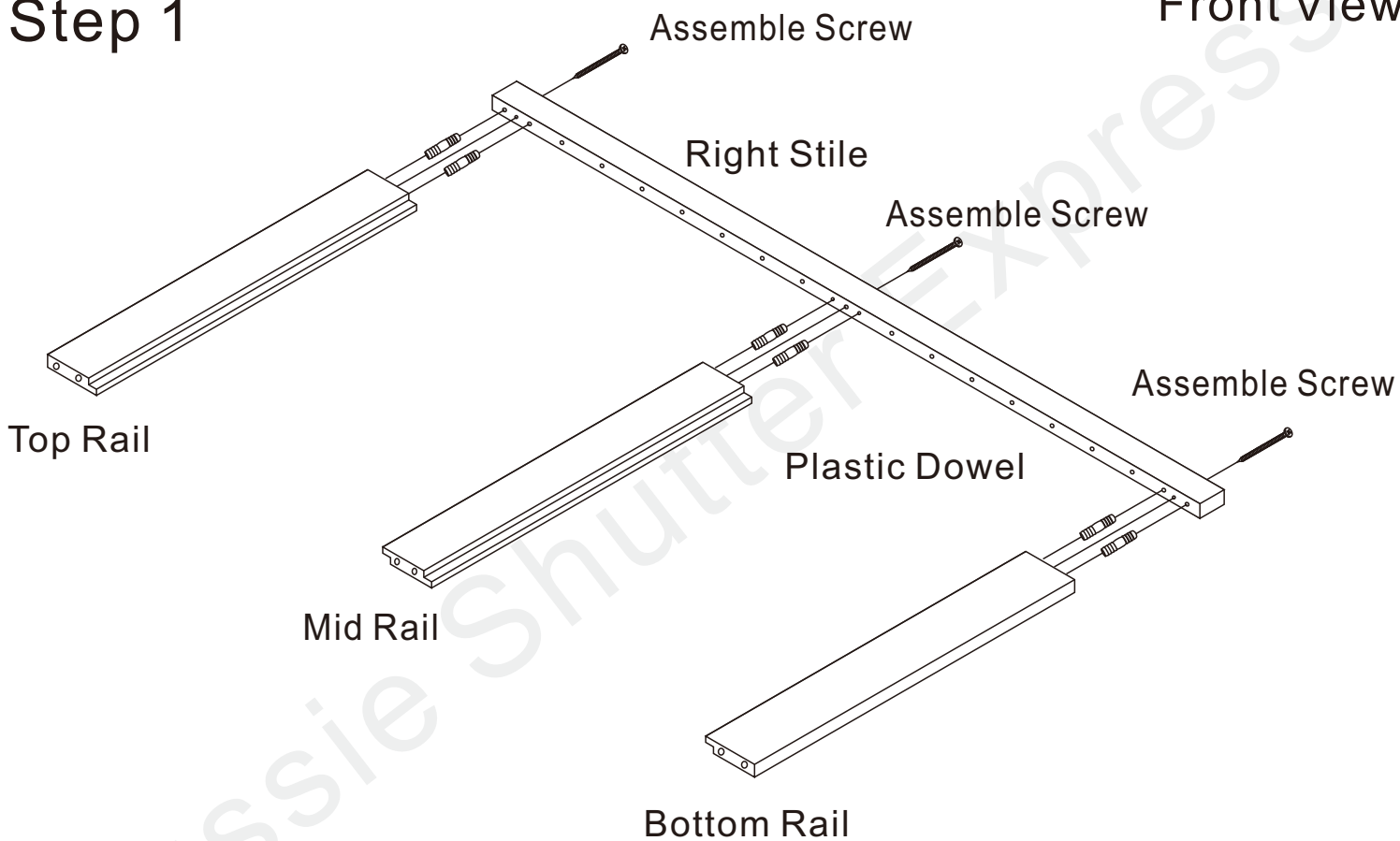

Step 2

Front View

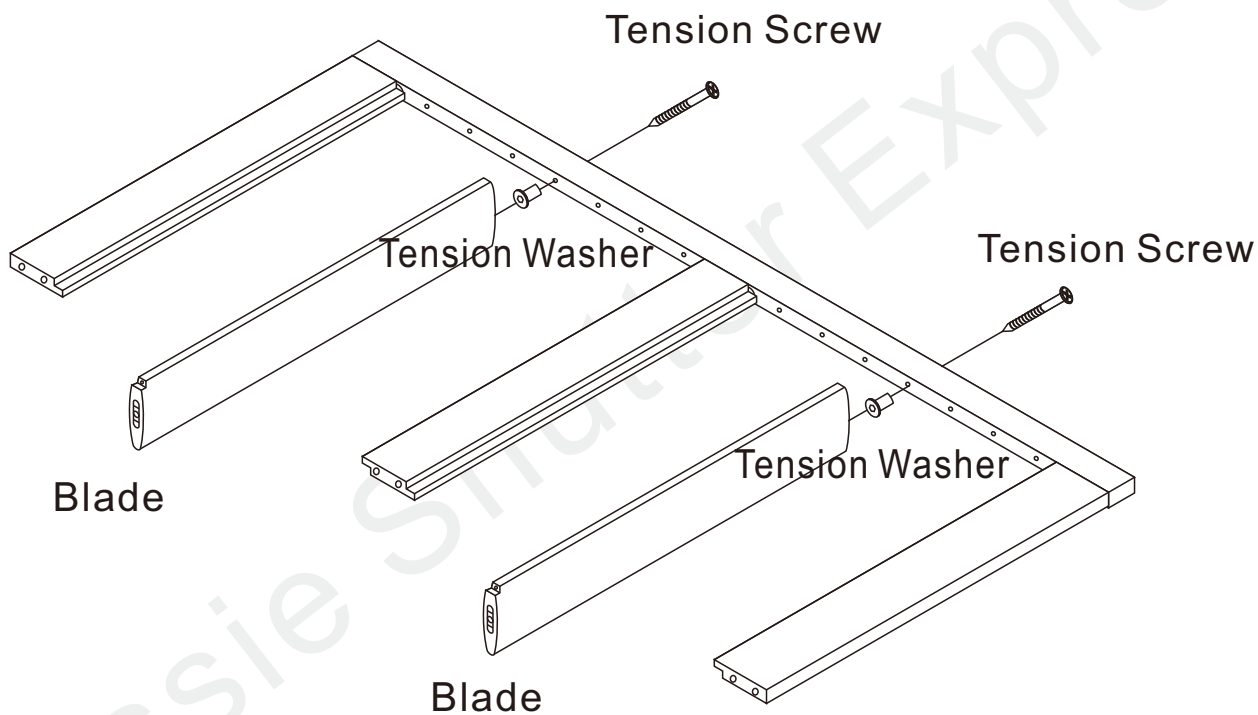

Step 3

Front View

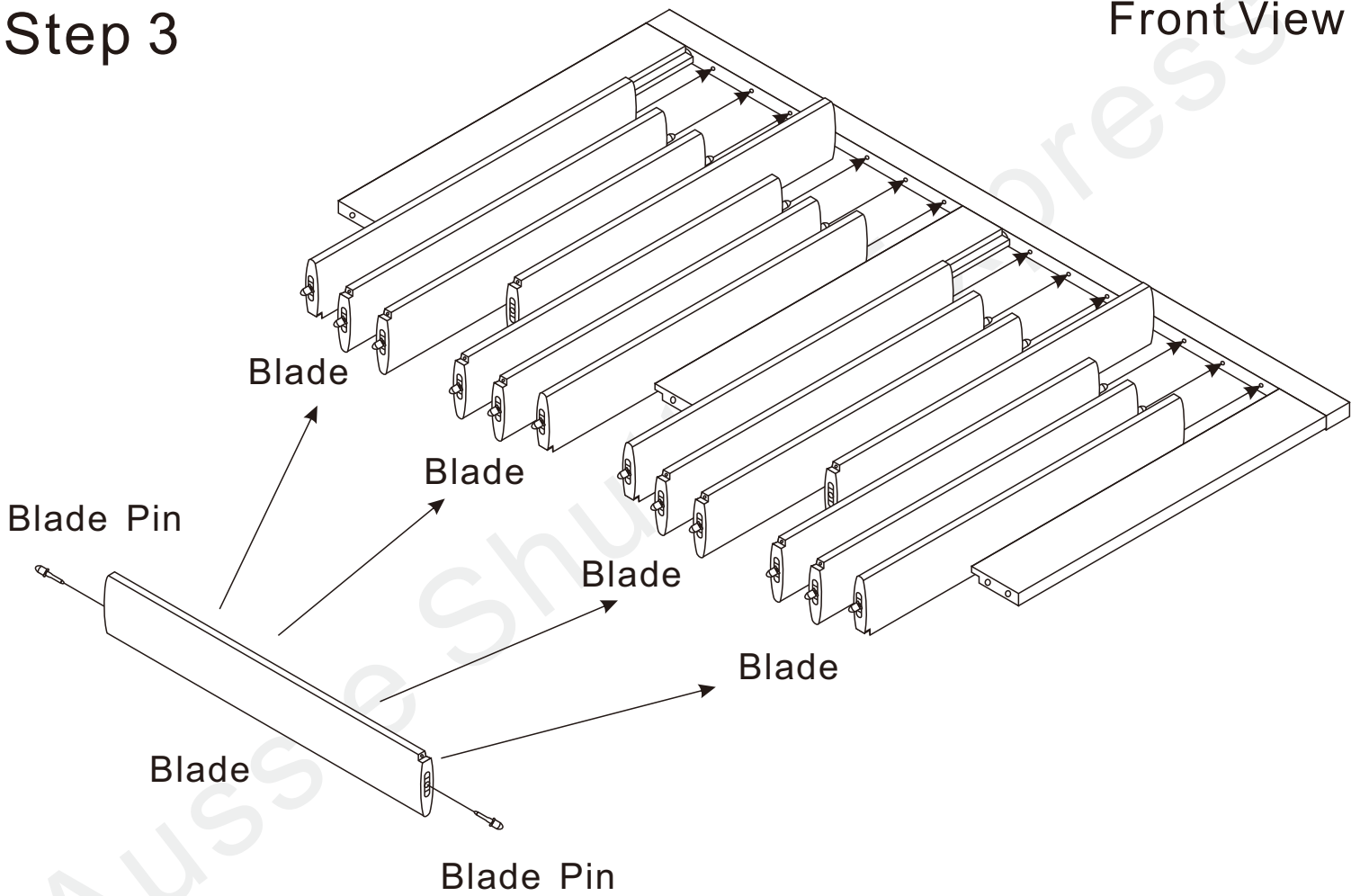

Step 4

Front View

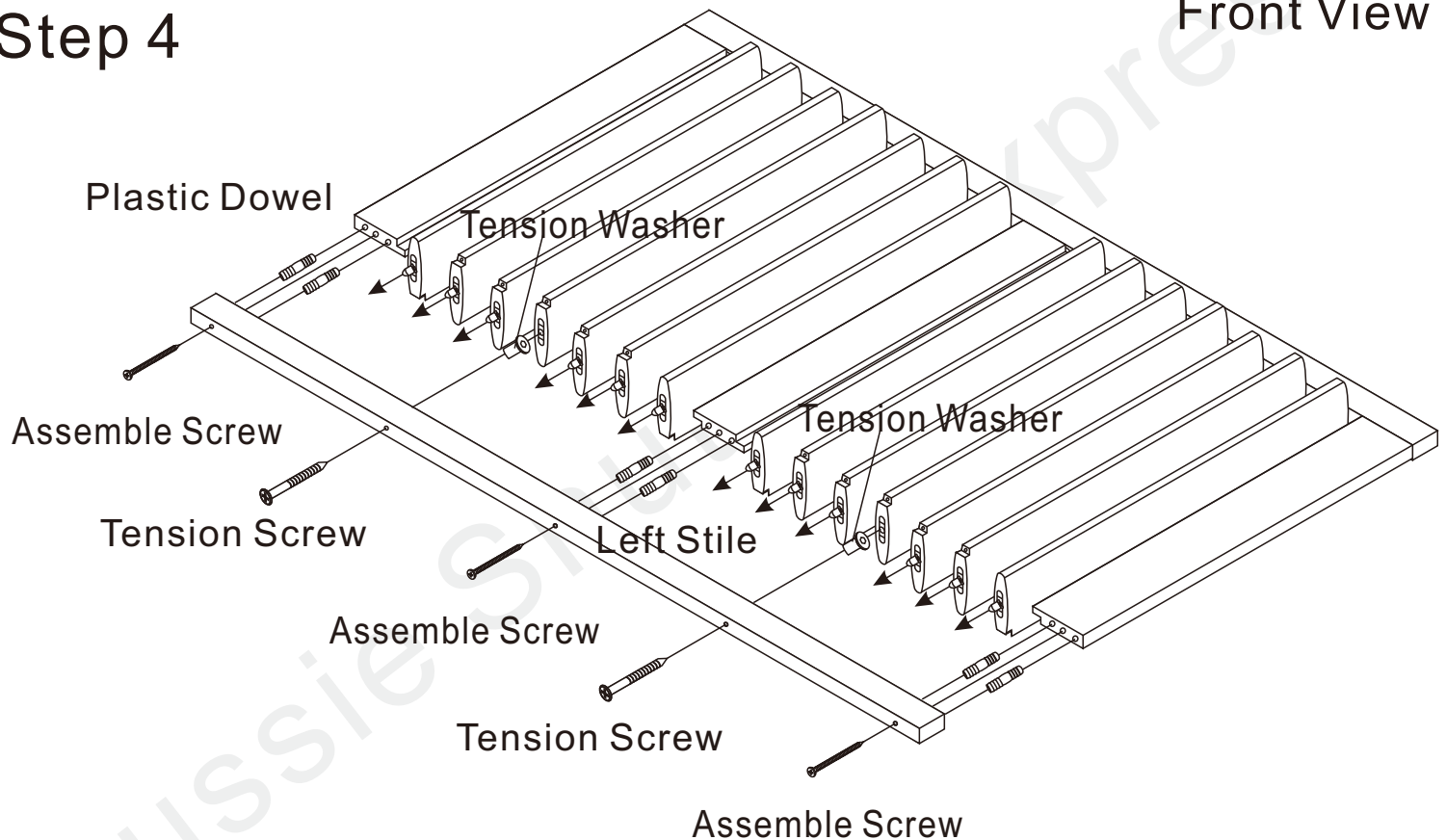

Step 5

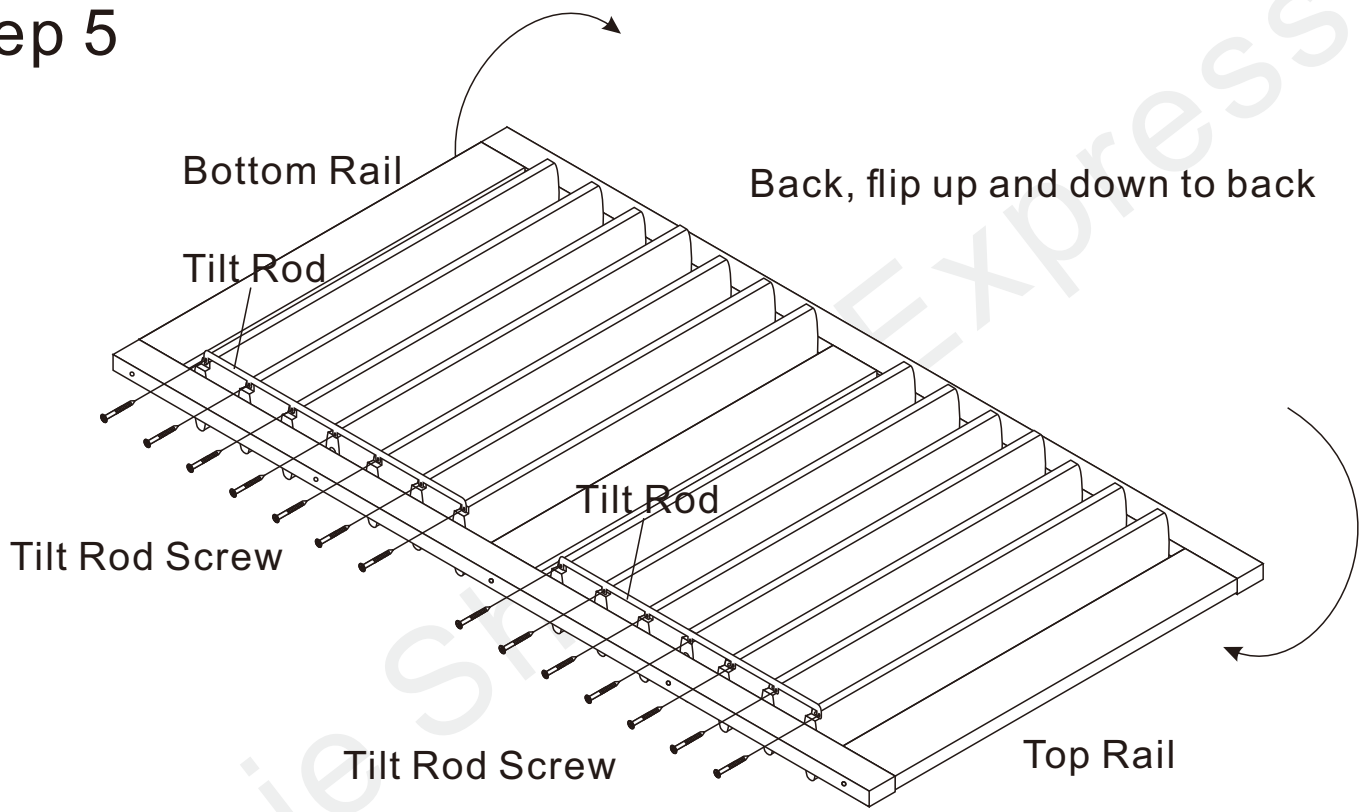

Step 6

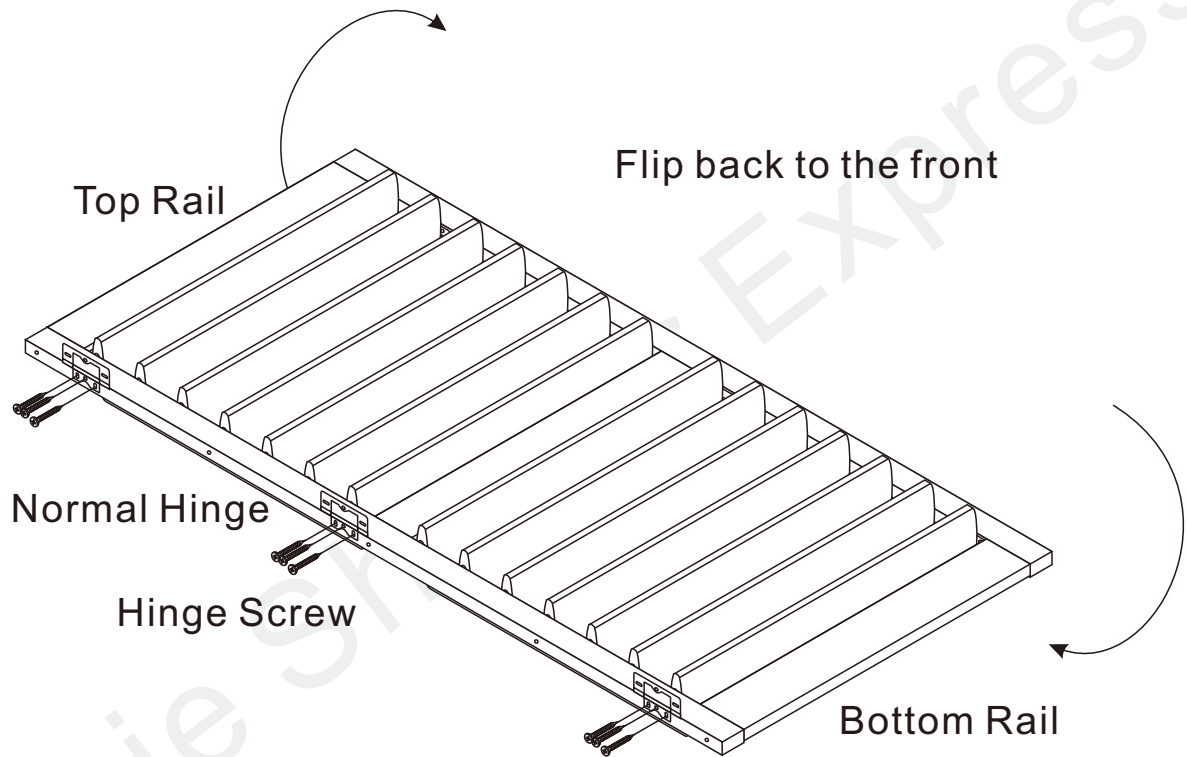

Step 7

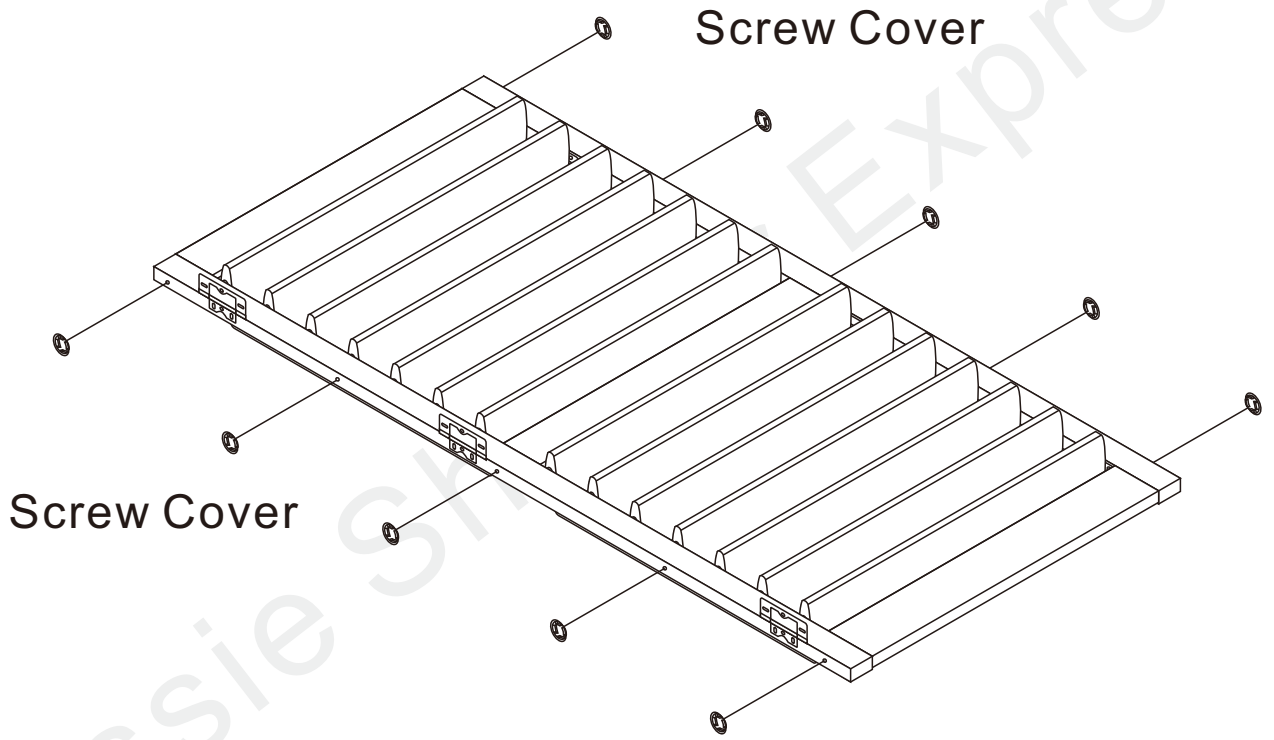

Front View

Step 8

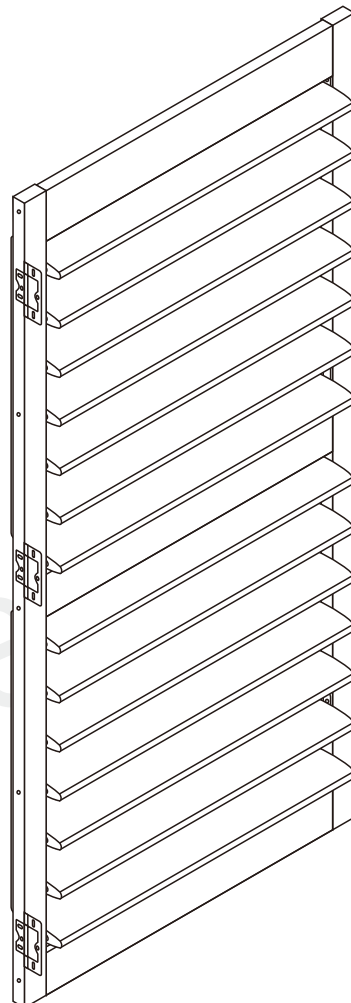

Front View